

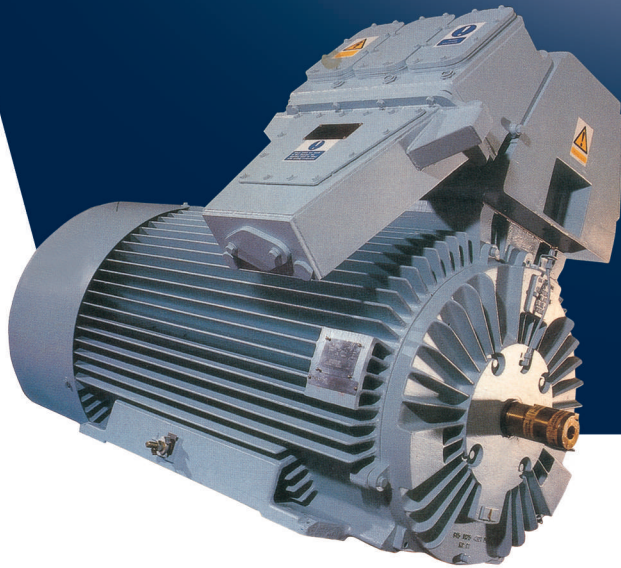

marathonTM
Motors

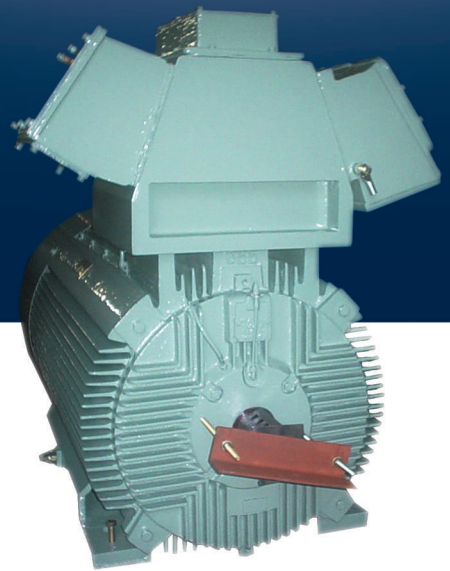

Flowpak 2



Flowpak 3

Flowpak Series

Totally Enclosed Fan Cooled
High Voltage Cage Induction
Motors

A Regal Brand

REGAL

www.regalbeloit.com

Design and operational features include :

High efficiency - upto 97% (For Flowpak 2) and 96% (Flowpak 3)

Low noise level (MSPL) - upto 85 dB (A) at 1 mt. distance with silence arrangements

Low stg. current - upto 550% for 4 Pole

High torque - 80% Voltage Starting on load "square low" drives

Short manufacturing cycle - 12 Weeks

High flexibility - detailed study of market requirements

Low Cost - Internationally Competitive.

Flowpak motors are part of an integrated range of induction machines, manufactured in a modern production facility dedicated to total quality.

Flowpak is a range of totally enclosed fan cooled cage induction motors available horizontally or vertically mounted for connection to supply voltages up to 6.6 kV, outputs upto 800 kW.

The Flowpak2 range has three frame sizes with shaft heights 280, 315 & 355 mm and Flowpak 3 range has also three frame sizes with shaft centre height 315, 355, 400, 450 & 500 mm. Standard designs cover 2 to 10 pole speeds and all sizes / speeds are all sizes/speeds are available with grease lubricated rolling element.

The MARATHON Electric Flowpak range of induction machines has been available for many years and has been widely accepted throughout the world for use in a wide range of

arduous industries.

A policy of continuous improvement has allowed the machine to remain competitive in on aggressive international market and the latest developments described in this brochure will secure a future well into

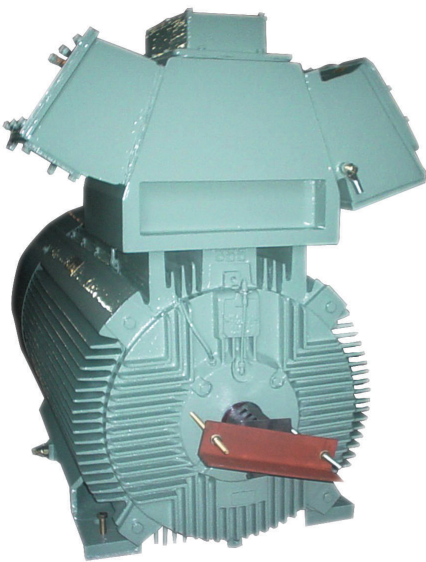

Flowpak 3

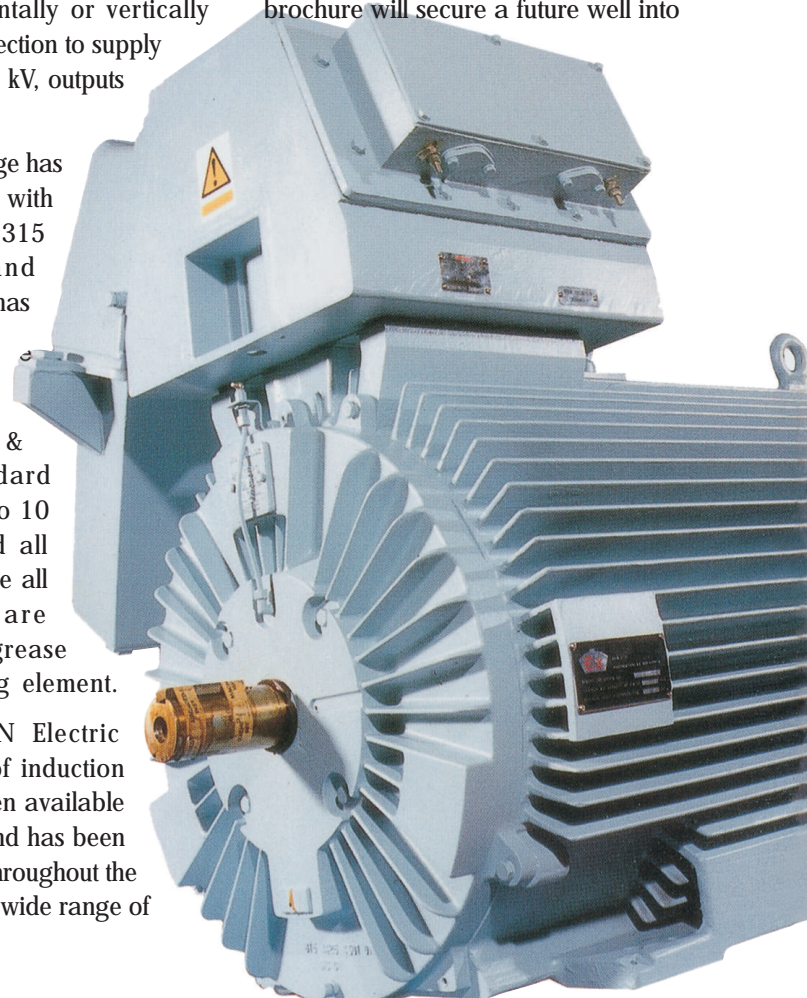

Standards and Specifications

POWER OUTPUT

50 Hz

60 Hz

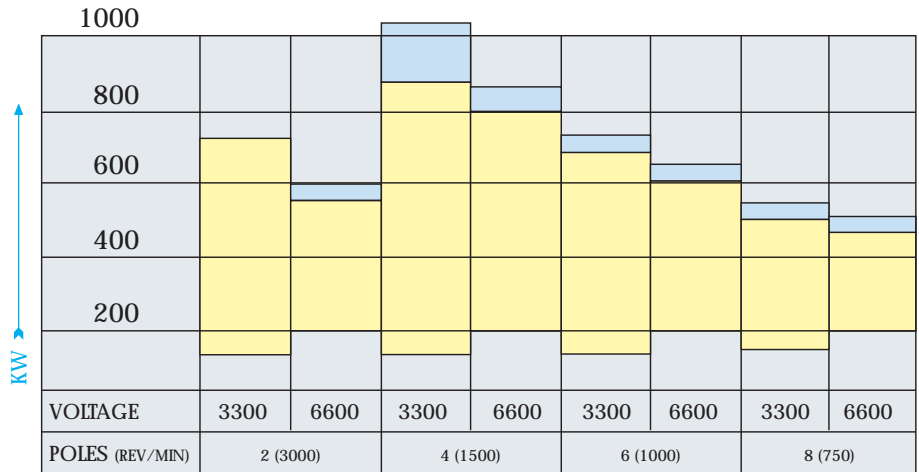

the next century.

Ratings & Performances

Flowpak motors comply with the requirements of IEC 34-1, the relevant parts of BS4999 and BS5000, IS:325 & other relevant Indian standards. They are designed for continuous duty corresponding to Duty Type S1 of IEC 34-1 and BS4999, part 101 section 3, with a temperature rise by resistance not exceeding 80K in a maximum ambient temperature of 40°C. The standard rated outputs are taken from the R40 series of preferred numbers in accordance with the requirements of clause 7 of BS4999 Part 101 and Part 1 of IEC 34-1. For enquiries with intermediate ratings the next highest preferred rating will be offered and performance data will be quoted accordingly. This maximises the cost and lead time

benefits available from the range design

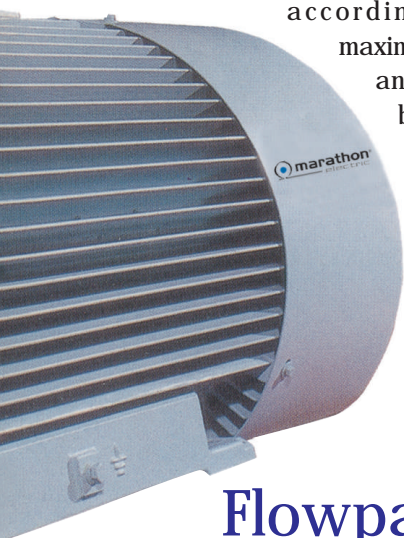

Flowpak 2

concept.

Dimensions

Dimensions are in accordance with BS4999 Part 141, IEC 72 and 72A.

Degree of Protection by Enclosure

All motors in the Flowpak range have a degree of protection IP55 as standard, conforming to the requirements of IEC 34-5, BS4999 Part 105 & IS:4691. This is defined as dust protected and suitable for operation in heavy seas (ships deck duty).

Method of Cooling

The standard of cooling form as defined within BS4999 Part 106, is IC 0141 - totally enclosed fan cooled. (The equivalent IEC 34-6 nomenclature for this enclosure type is IC411).

Forced ventilation (IC 416) is also available, suitable for constant torque V.F.D. (690 V) application.

Mounting

Mounting designations are in accordance with IEC 34-7 Code 11 and BS4999 Part 107. The standard mounting arrangements available on all frame sizes are.

IM1001 - Horizontal foot

IM3011 - Vertical flange

IM2001 - Horizontal foot and flange

Supply

Standard ratings are based on supply voltages of 3300 or 6600 volts on a 50 Hz supply frequency and 2300 or 4160 volts on a 60 Hz supply frequency. Other voltages and frequency combinations one available on request.

Insulation

The winding insulation system is class F in accordance with IEC 85 and BS2757. More detailed information on insulation & Vacuum Pressure and Impregnation (VPI) systems/processes are available on request in a separate publication entitled Resivac - The VPI insulation system.

Special Applications

The range design has been developed other considering many industry



Flowpak 3

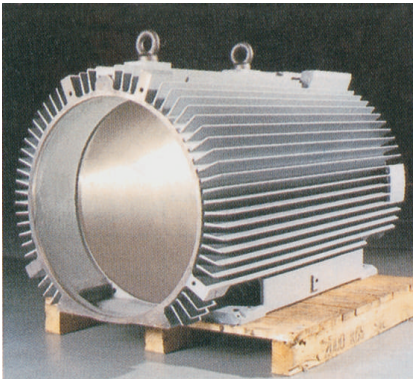

Flowpak 2

standards and most requirements can be met with the range standard plus standard optional extras.

Stator Frame and Endshields

Stator Frames and endshields are produced from high grade cast iron with deep external cooling ribs. Spigotted Endshields are fitted to the frame and incorporate the bearing housings.

Motor feet, terminal facings and two lifting eyebolt bosses are cast integral with the frame. Horizontal frames also have jacking screw provision and pilot dowel holes as standard.

The Flowpak range of machines have permanently fixed air gaps achieved by close tolerance machining of all components.

Bearings

The standard bearing arrangement has C3 internal clearance metric rolling element bearings that are mounted directly into the bore of the endshield. Premium quality lithium based grease containing oxidation and corrosion inhibitors is used and pressure grease relief facilities are a standard feature. All rolling element bearings have long

Construction

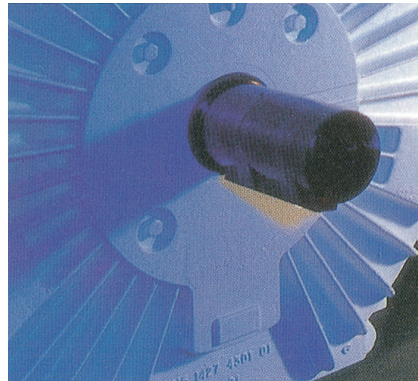

relubrication intervals and an L10 bearing life of greater than 40,000 hours.

Self contained or flow lubricated plain bearings can also be fitted if required. Flow lubricated plain bearings are fitted with inlet and outlet flanged stub pipes, for connection to an oil supply provided by others.

On vertically mounted motors the rotor weight is supported by the top bearing which would either be of the deep groove ball or duplex type depending on the axial loading to be accommodated.

All bearings used are of the highest quality produced by internationally recognised manufacturers ensuring spare parts are readily available. An insulated bearing arrangement can also be provided on request.

Motor bearings have been selected on the basis that the machines are directly coupled, without external thrust being imposed by the driven equipment. If

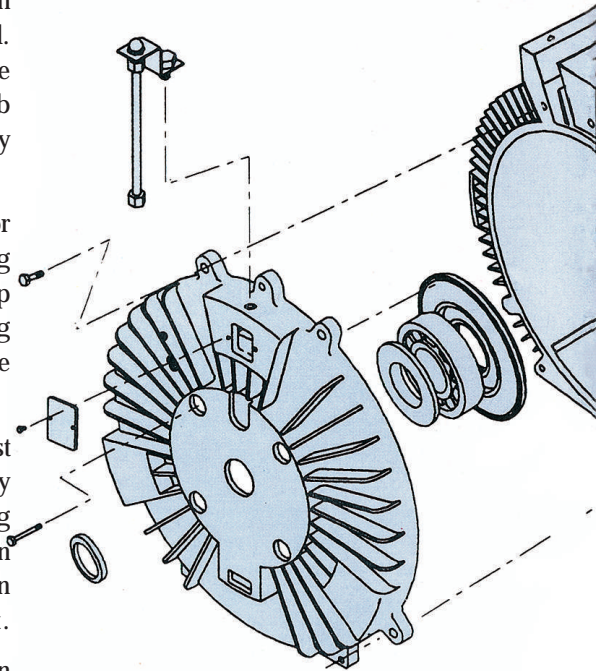
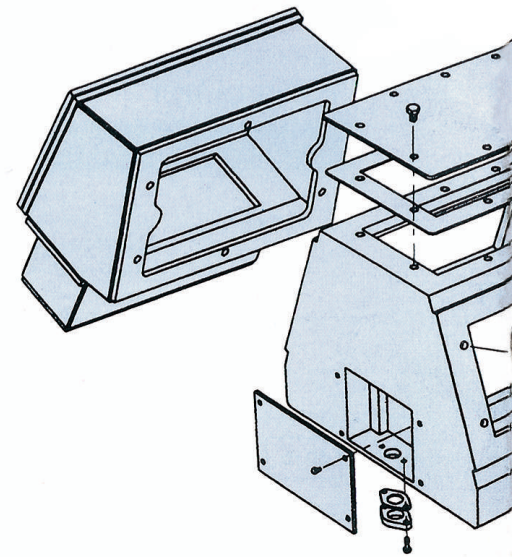

Flowpak

Basic Dimensions of FLOWPAK-2 Motors

FRAME	POLES	A	B	D	E	H	HD	AE	C	L*
DC280 F710	2	457	710	75	140	280	1071	1067	190	1700
	4-12	457	710	75	140	280	1071	1067	190	1700
DC315 F800	2	508	800	75	140	315	1146	1102	216	1825
	4-12	508	800	95	170	315	1146	1102	216	1855
DC355 F900	2	610	900	75	140	355	1226	1142	254	2100
	4-12	610	900	95	170	355	1126	1142	254	2130

* L may be increased by 200 mm (approx) for silencer arrangement. Detail to be confirmed after receipt of order.

NOTE : All motors are with Antifriction rolling element bearings.

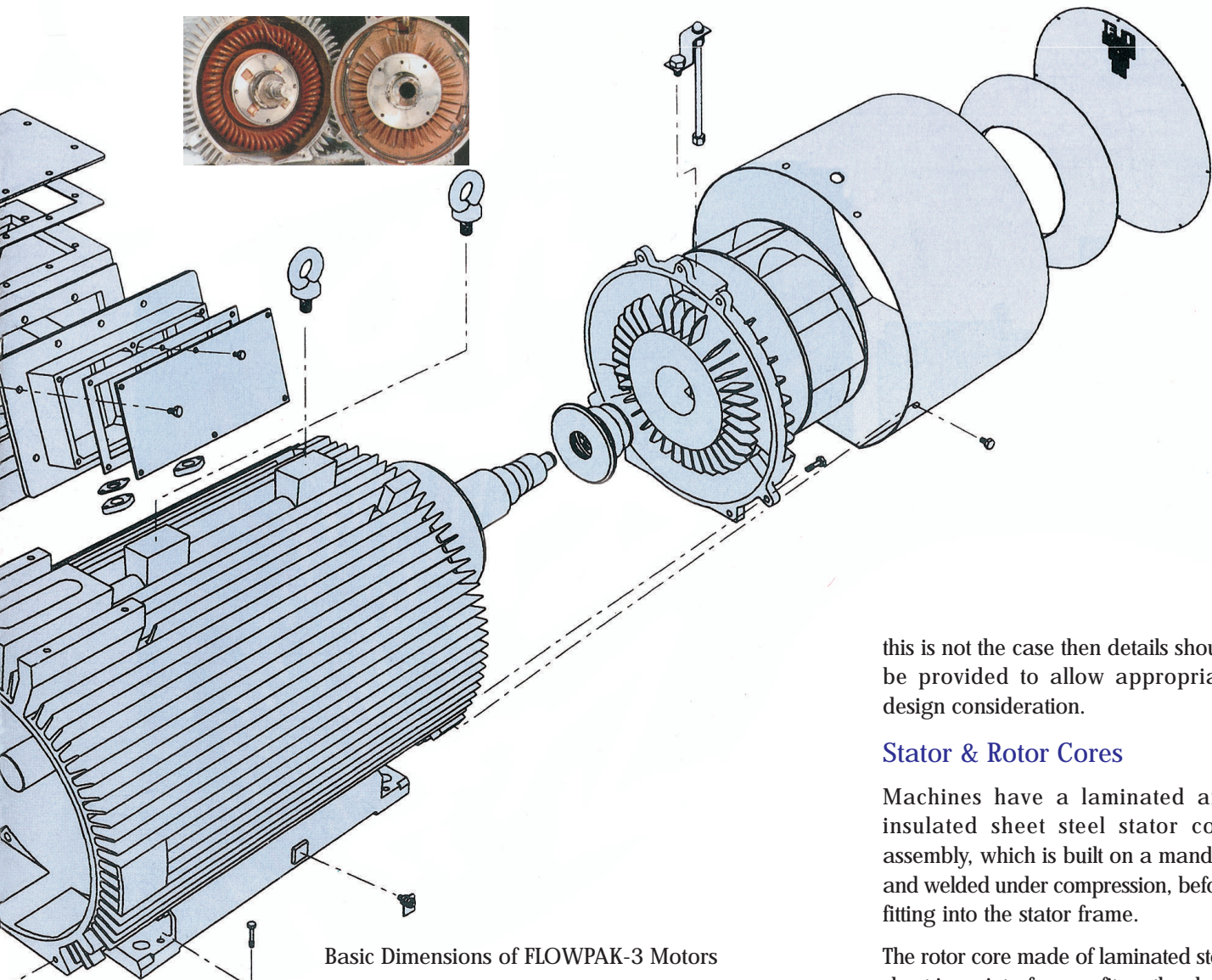

Basic Dimensions of FLOWPAK-3 Motors

FRAME	POLES	A	B	D	E	H	HD	AE	C	L*
DC315 F3	2	508	800	75	140	315	1146	1102	216	1780
	4-12	508	800	95	170	315	1146	1102	216	1810
DC35 F3	2	610	900	75	140	355	1226	1142	254	2050
	4-12	610	900	95	170	355	1126	1142	254	2080
DC400 F3	2	686	1000	80	170	400	1336	1182	280	2330
	4-12	686	1000	100	210	400	1336	1182	280	2370

* L may be increased by 200 mm (approx) for silencer arrangement. Detail to be confirmed after receipt of order.

NOTE : All motors are with Antifrication rolling element bearings.

For dimensions of frame size 450, 500 please refer to works.

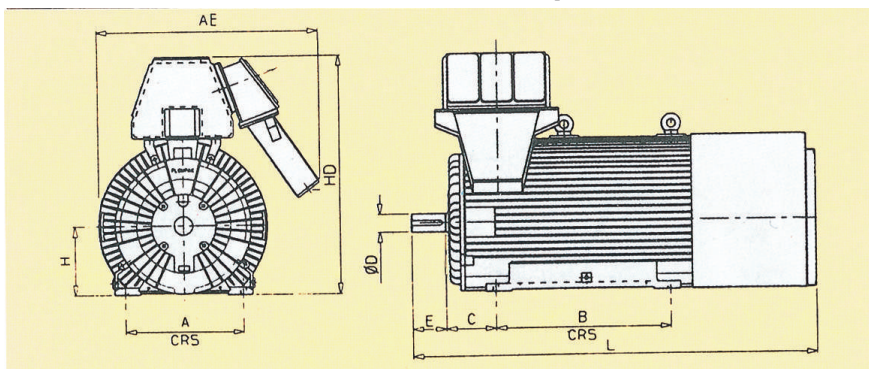

this is not the case then details should be provided to allow appropriate design consideration.

Stator & Rotor Cores

Machines have a laminated and insulated sheet steel stator core assembly, which is built on a mandrel and welded under compression, before fitting into the stator frame.

The rotor core made of laminated steel sheet is an interference fit on the shaft. The core is compressed between fabricated steel endplates and the assembly is then securely locked into position with a steel key ring.

Stator Coils

Stator coils are formed from annealed copper strip, insulated with mica. Loops of the appropriate number of turns are formed, the coil straight portion is bonded and the loop is then pulled to shape. The coil is insulated with layers of mica tape, dependent on voltage, prior to the application of the finishing tapes.

Coil Connections and Bracing

The coils are inserted in the slots, and firmly wedged in position with epoxy glass or magnetic slot wedges.

Construction

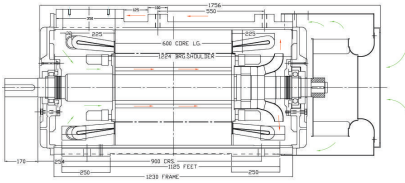

Flowpak 3

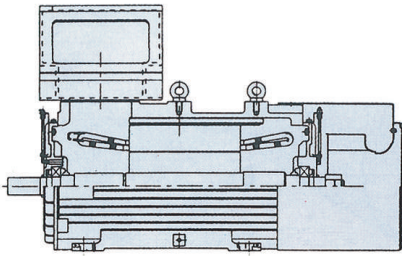

Flowpak 2

Endwindings are securely braced to prevent movement during service. Strict quality control is exercised during the winding process.

The winding is high voltage tested at both mains and high frequency immediately after the coils are inserted and wedged, and again after connecting. On completion of winding phase resistances and impedances are checked for balance and conformance with design.

Impregnation

Flowpak stators are Vacuum Pressure Impregnated (VPI) with an epoxy resin.

The VPI system utilises materials with a minimum resin content at the winding stage, and places greater emphasis on the final impregnation treatment. This not only extracts all air from the winding, but also forces the resin, under pressure, into the interstices of the coils until they are totally filled. All coil packings retain a high proportion

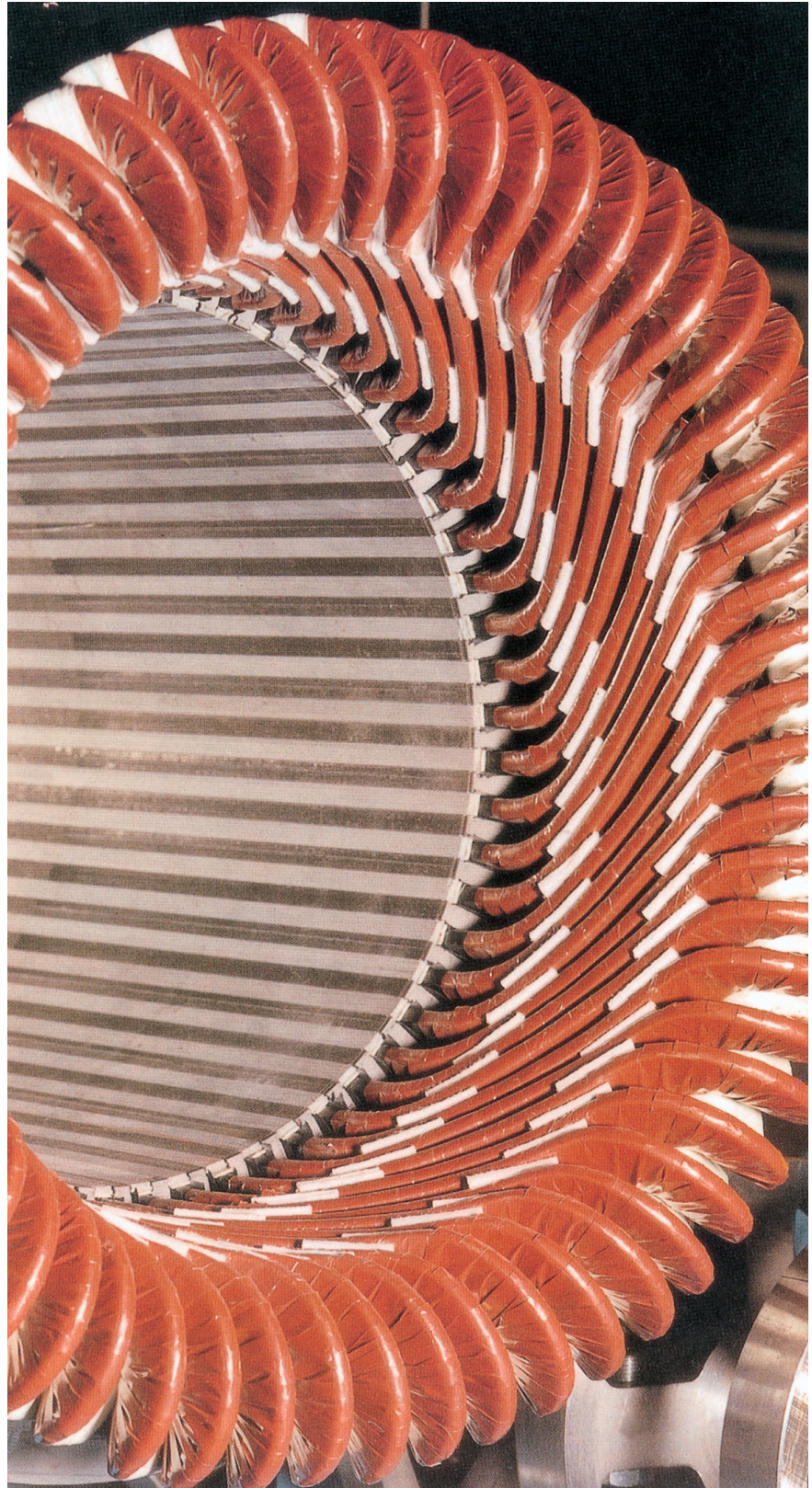

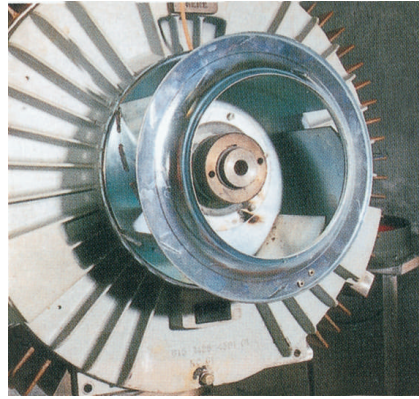

of resin and the connections become one consolidated ring after rotate curing in time and temperature controlled ovens.

After impregnation the windings are subjected to the voltage tests specified in BS4999 Part 101, section 9. All machines one subject to loss tangent tests.

Rotor Bars

All motors have copper or copper alloy rotor cages. Tight fitting rotor bars are butt brazed to copper or copper alloy endrings. All rotors are dynamically balanced to more stringent levels than those specified in ISO2372. Overall motor vibration severity does not exceed the limits specified in IS:12075.

Shafts

Shafts are manufactured from carbon manganese steel of grade 150M28 to BS970 or equivalent. Standard motors have a single plain parallel shaft extension with a single keyway and motors are balanced with a half key fitted. The shaft extension is drilled and tapped in accordance with BS4999 Part 141.

Fans & Cowls

Flowpak 2 motors are fitted with unidirectional low noise level fans manufactured from galvanised steel. Fan cowls are also manufactured from steel. For Flowpak 3, one additional internal fan is used in place of wafer to get more thermal efficiency.

Terminations

Unless otherwise specified, motors are supplied with a single fabricated steel, air insulated terminal box (for 3.3 kV) containing three mains terminals suitable for direct-on-line starting. The box is mounted on the side of a top mounted adaptor and is supplied with a blank gland plate. Special glands can be supplied to order. Phase segregated terminal box is provided for 6.6 kV Motors and for 3.3 kV Motors on request. A wide range of alternative boxes are available.

When specified, access to the winding neutral point can be provided by removal of a steel cover or within a separate terminal box.

The prospective system fault level should be advised to enable selection of the most suitable terminal arrangement.

Auxiliaries

Flowpak 2 range allows the flexibility of fitting a wide variety of instrumentation and auxiliaries including winding and bearing temperature sensing elements, vibration transducers, anti-condensation heaters and silencing elements.

Flowpak 2

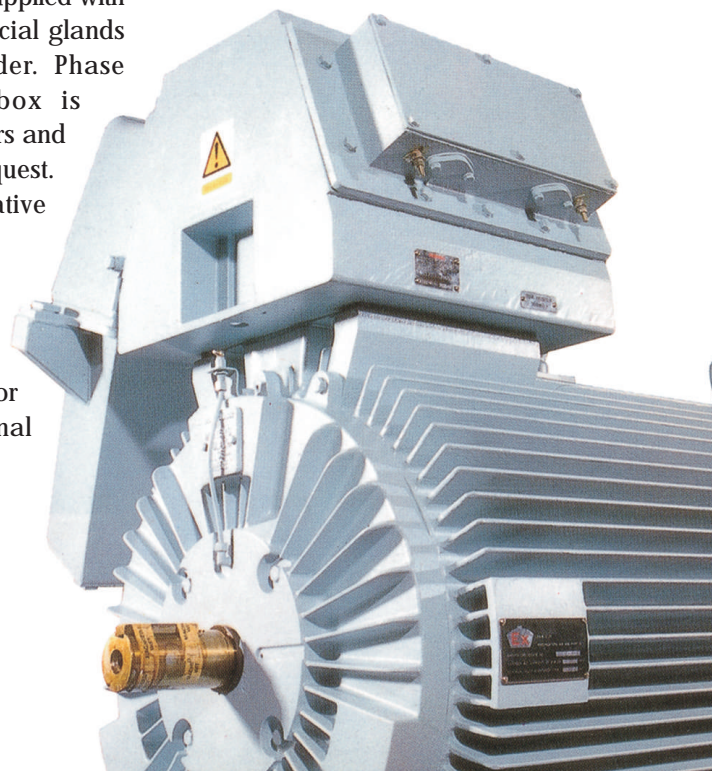

Manufacturing Facilities



Latest computer hardware & software available with Auto CAD facility in Design office.

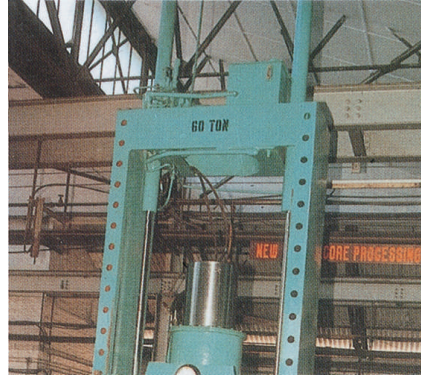

Vertical press installed for accurate rotor core building.



Air-conditioned dust free facility provided for coil making and insulation taping.

Separate ancillary terminal boxes can be arranged on the top mounted terminal box adaptor.

Facilities

MARATHON Electric has implemented major restructuring of facilities. The new equipment together with the introduction of upgraded CAD facilities has laid to significant reduction in delivery lead times.

Operational flexibility has also improved and the introduction of 'World Class' systems has enabled the Company to introduce many product improvements.

The recent restructuring has transformed the Kolkata Plant into designated production flow lines for H.T. and L.T. Products.

Upgradation of test facilities will enable us to test motors upto 4000KW, 11KV, 4 pole.





Dust free facility installed for Motor winding.

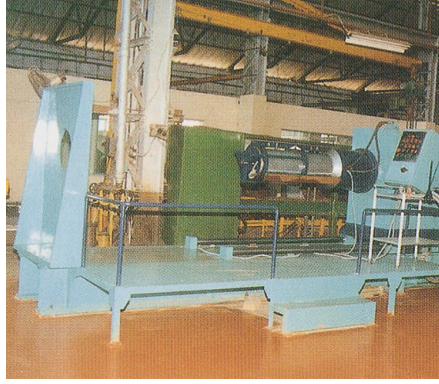

Core Insertion Machine installed for insertion of wound core into frame.

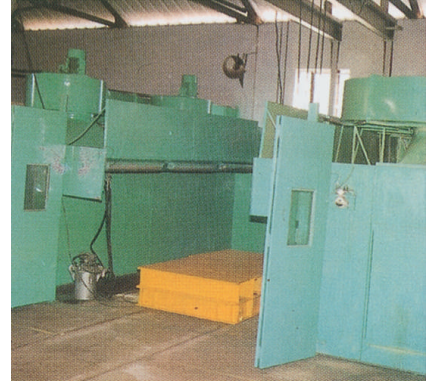

Spray painting booth



Vacuum Pressure & Impregnation Plant

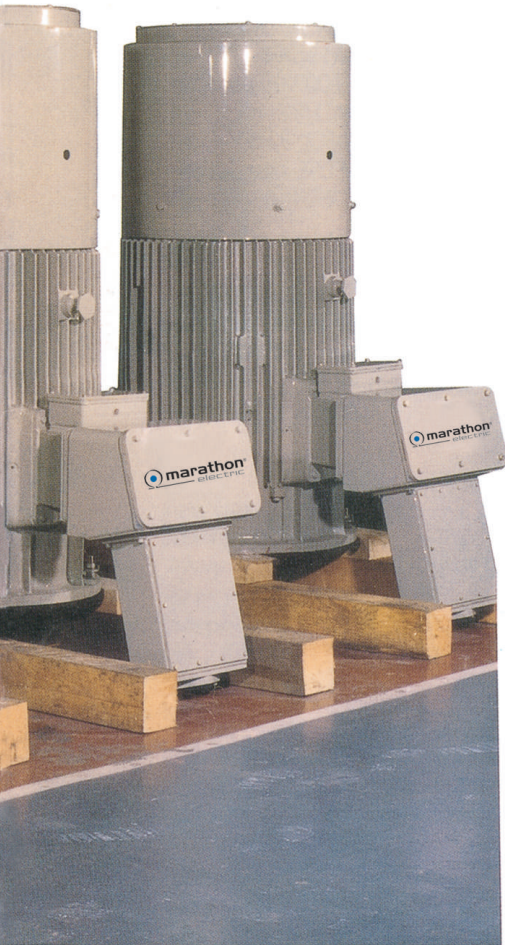

Flowpak 2

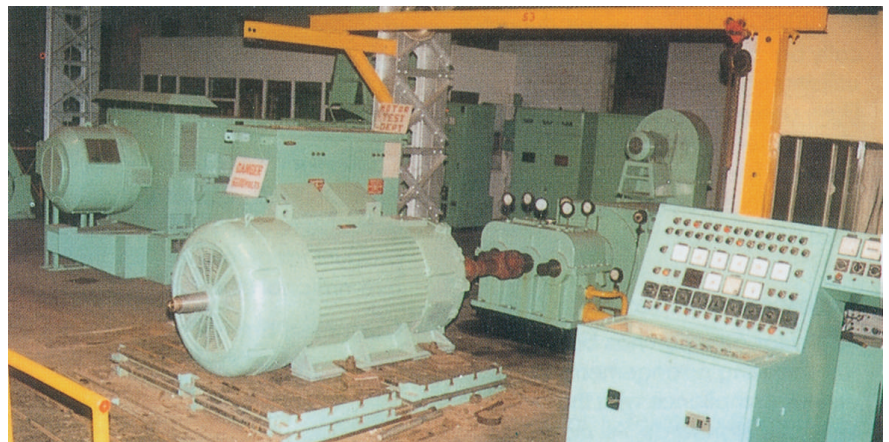

Test Plant

Testing

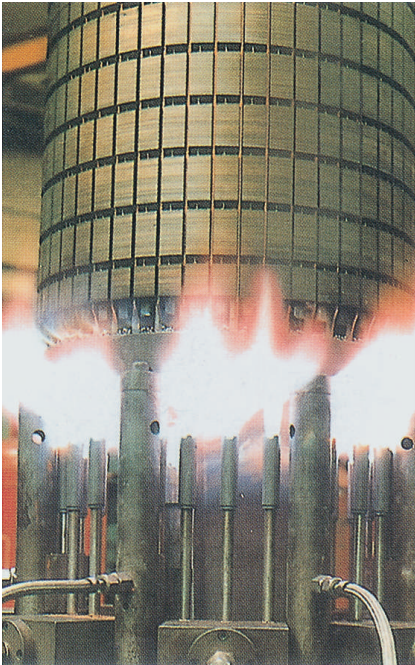

One shot Rotor brazing



Coil Testing Laboratory



Balancing M/C

The introduction of new facilities has improved production and manufacturing effectiveness.

Noise

The Flowpak range has been designed with a low overall noise level. Using special Silencer to meet a noise level of 85 dB (A) at a distance of 1 mtr.

Vibration

Motors in the Flowpak range including 2 pole machines, meet the specified standard of vibration of IS:12075. Rotors are dynamically balanced at more or less rated RPM utilising two planes in areas of likely unbalance. Vibration is then checked on test at full speed and where a full test is required this is done before during and after the heat run.

Enclosure Protection

Particular attention has been paid to all sealing arrangements to ensure

compliance with the specified standards. All machines in the range have IP55 protection as standrd.

Paint System

Surfaces are degreased then cleaned to ISO 8501 and ISO 8503, which define surface cleanliness and roughness.

Surfaces are then primed using a modified synthetic resin red oxide primer to a dry film.

A single finish coat of two pack Epoxy paint is applied.

Total Quality

The complete range of HT Motors are manufactured to a Quality Assurance plan which lays down stringent acceptance norms for each stage of production.

All materials are critically tested in-house to ensure the Flowpak 2 product range meets National and International standards.

Customers are welcome to carry out stage inspection or final inspection during manufacture.



CMM M/C

Flowpak

marathon[™]
Motors



Paharpur Works
58, Taratala Road
Kolkata - 700024
Ph: 91 33 4403 0400
Fax: 91 33 2469 5369/8530

AEI Works
1, Taratala Road
Kolkata - 700024
Ph: 91 33 4403 0500
Fax: 91 33 2469 6988

www.marathonelectric.com

A Regal Brand



www.regalbeloit.com